

# RAPTOR MINI DH





# RAPTOR MINI DH

Long Hole Rig For Narrow Vein

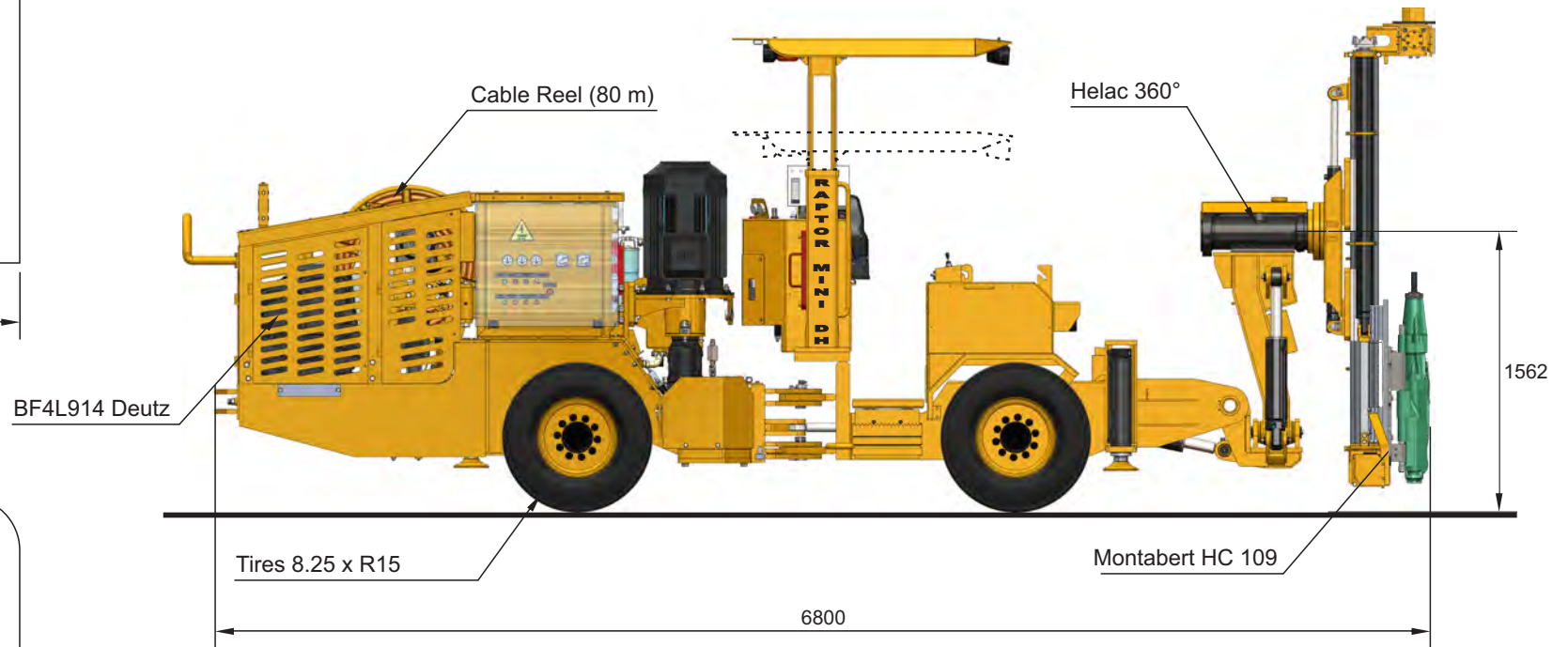
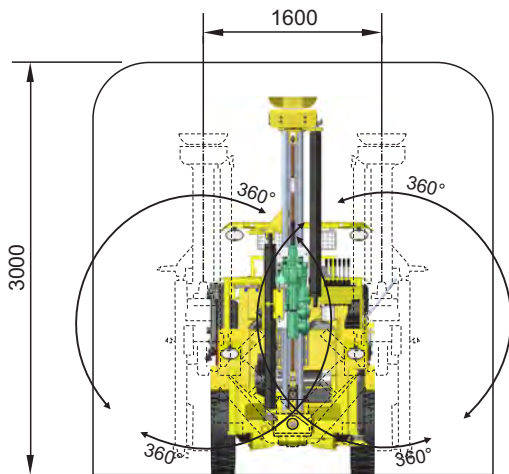
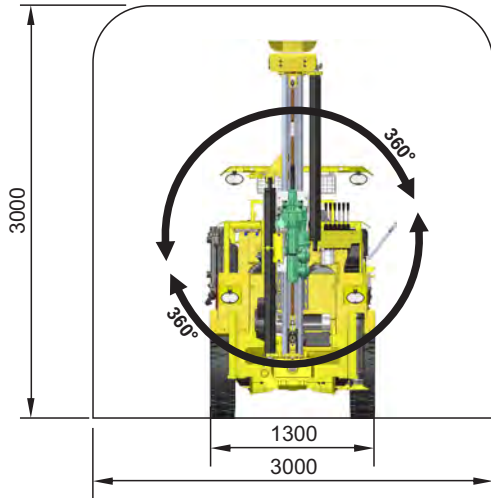

- ✓ Diameters up to 76 mm, reaming 102 mm, lengths up to 25 meters
- ✓ Parallel holding coverage 1.60 m, fan drilling 360°
- ✓ Sections from 2.7 x 2.7 up to 4 x 4 m
- ✓ Sublevel Stopping, Sublevel Caving, benching
- ✓ Cable bolting application
- ✓ Productivity up to 12,000 meters / month.  
(depending on other factors from the mine)

### Dimensions

- . Width : 1.30 m
- . Height : 2.60 m (minimun 2.0 m.)
- . Long : 6.80 m
- . Weight : 7,400 kg

# Main Specifications

## Drilling System

- HC 109 Montabert drifter 19 kW, option HC 50 (13 kW)
- Long hole feed 2500 series, two Stingers, heavy duty hydraulic clamp
- Available for 3, 4 and 5 ft drilling rods; total length 2.50, 2.80 and 3.12 meters respectively
- Sauer Danfoss Hydraulic motor and 100H chain
- Transverse displacement, 1.60 m effective parallel coverage through Pendulum Arm
- Helac Rotary actuator, 360°
- MR-12 Panel remote drilling control with Allen Bradley/Rockwell components
- 75 kW power pack, ABB motor and A10VO100 Rexroth pump + Parker gear pump
- Anti jamming system
- Water pump, 3 kW Grundfoss
- LE3-10 compressor for drifter air lubrication
- Transtronic Digital Inclinometer

## Carrier

- 4WD Heavy duty carrier, articulated, rear axle oscillating 14°
- Deutz BF4L914, 72 kW, air cooled
- FOPS Canopy certified
- Poclain hydrostatic transmission, 4 wheel motors and one Sauer pump
- Four tires 8.25 x R15
- Parking and service brake SAHR through same hydrostatic system
- Four hydraulic stabilizers jacks
- Cable Reel, 70 meters 130 amperes
- Electric box IP64, 550/ 440/ 380 volts, 60/ 50 Hz, Allen Bradley
- SKF Autolube
- ANSUL fire supressor
- One Spare tire and rim
- Parts, maintenance and operation manual, two copies and CD

